



## SECTION 3.12\_KSFE-A

# FLAME ARRESTER DEFLAGRATION PROOF END-LINE

### INTRODUCTION

 **The model KSFE-A** flame arrester are designed, manufactured and tested according to API2000, BS7244 (British Standard Specification) and ISO 16852. The units allow free venting in combination with flame protection for vertical vent applications. They prevent flame propagation by absorbing and dissipating heat using spiral wound crimped ribbon SS316L flame cells.

### Operating Temperature @ Pressure

KSFE-A / DN 15 ~ DN 100

+ 60°C (=140°F) @ 0.11 Mpa

 **Body Materials** Aluminium, Nodular Iron, Cast Steel, SS304, SS316, SS316L with various trims  
(Different materials available on request)

 **Sizes range** DN 15 ~ DN 100 with ASME 150Lb flanges(Different connections available on request)

 **Rules & certifications** API 2000, BS7244 / ISO 16852 & ATEX  
Flame cell : NEC group D (=IIA), group C(=IIB3) and group B(=IIC), ETC.

 **Optimum / optional Design & Arrangements** Stem Jacket type, Steam Tracing type

### APPLICATION

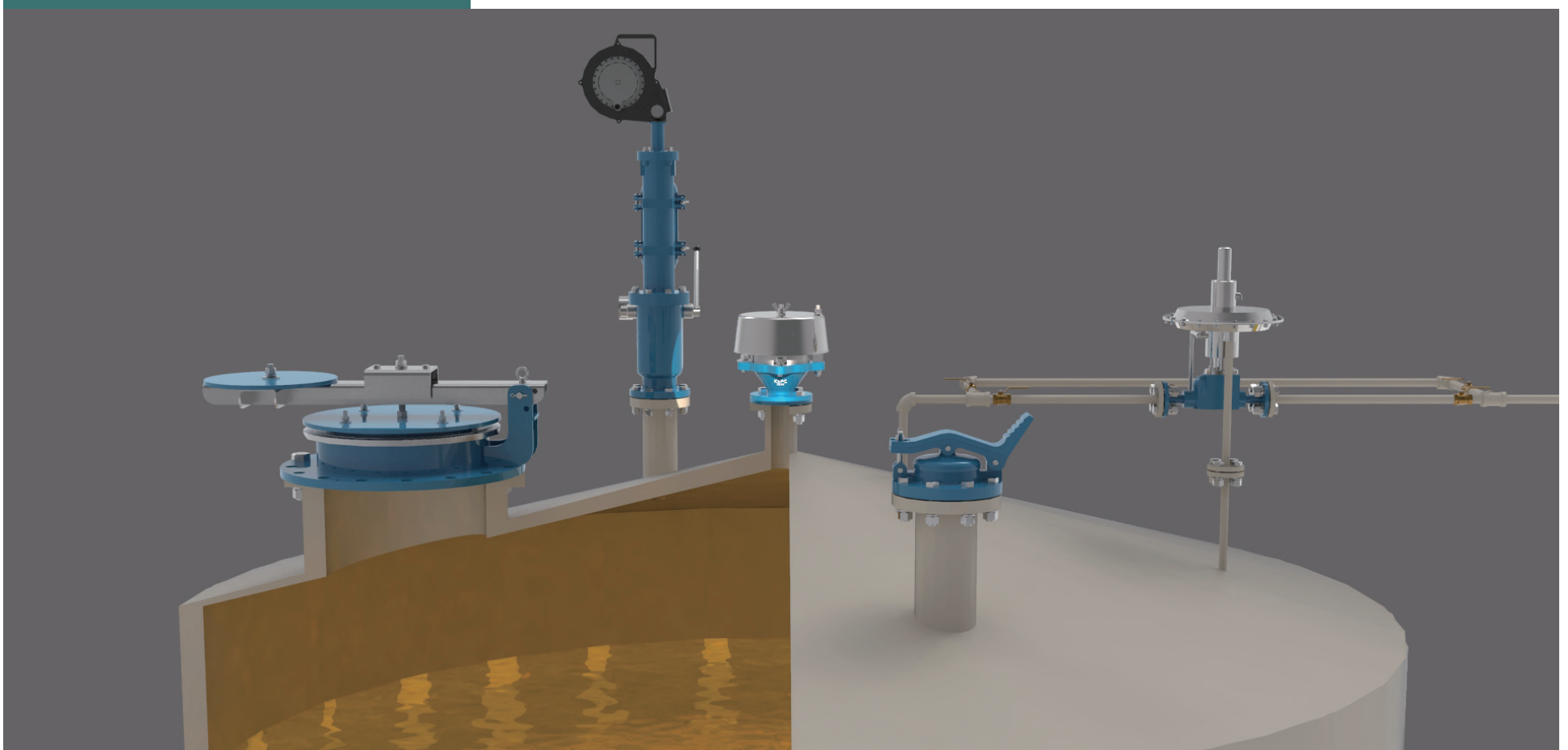

## OUTLINE DRAWING

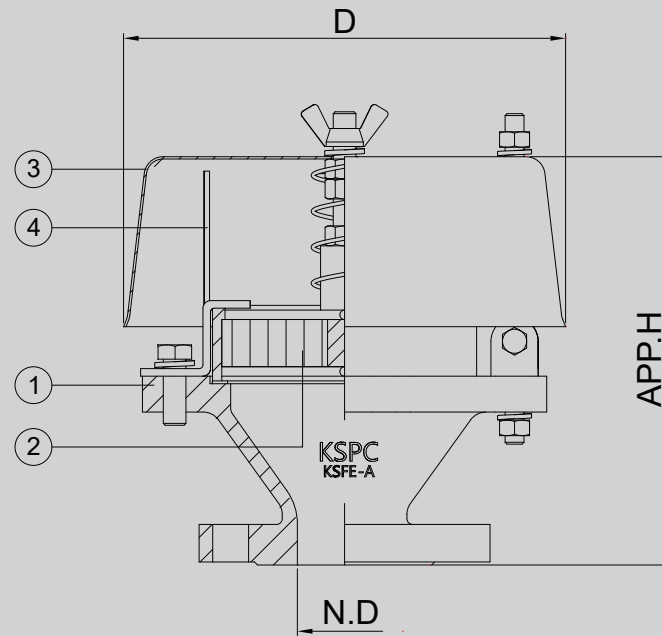

KSFE-A DN15 ~ 100

Section 3.12  
KSFE-A

## DIMENSION TABLE

SIZE	½"	1"	2"	2½"	3"	4"
N.D	15	25	50	65	80	100
D	234	234	234	234	288	342
Approx. H	220	223	226	229	237	260

**NOTE** Standard Connection(ASME 150Lb flange) and JIS or different types are available upon request.

## COMPONENT MATERIAL

ITEM NO	COMPONENT	ALUMINIUM	CARBON STEEL	STAINLESS STEEL
1	BODY	B216-319.F	A216-WCB	A351-CF8/ CF8M
2	ELEMENT	SS316L		
3	WEATHER HOOD	SS304	SS304	SS316L
4	BIRD SCREEN	SS304	SS304	SS316
STANDARD PAINTING		IN-OUT SIDE EPOXY 150 MICRON WITHOUT STAINLESS STEEL & ALUMINIUM PART		

## MAINTENANCE

- ⚠ Periodic inspection and maintenance is required. The cell assembly can be removed for cleaning purposes.
- ⚠ Cleaning can be accomplished by dipping the entire cell assembly into an appropriate solvent.
- ⚠ Care should be taken not to damage the cell openings as such deformations hamper the flow through the cell.
- ⚠ The gaskets should be inspected and replaced if necessary.