



## SECTION 3.3\_KSFI-J

# FLAME ARRESTER DEFLAGRATION PROOF IN-LINE

### INTRODUCTION

**The model KSFI-J** inline flame arrester is designed, manufactured, tested according to API 2000, British Standard Specification Code BS7244 and ISO 16852. The units are passive devices with no moving parts. They prevent the propagation of flame from the exposed side of the unit to the protected side by the use of a 316L stainless steel crimped metal ribbon type flame cell element. This construction produces a matrix of uniform opening that are carefully constructed to quench the flame by absorbing the heat.

### Operating Temperature @ Pressure

KSFI / DN 15 ~ DN 600

+ 60°C (=140°F) @ 0.11 Mpa

**Body Materials** Aluminium, Nodular Iron, Cast Steel, SS304, SS316, SS316L with various trims  
(Different materials available on request)

**Sizes range** DN 50 ~ DN 300 with ASME 150Lb flanges  
(Different connections available on request)

**Rules & Certifications** API 2000, BS7244 / ISO 16852 & KFI  
Flame cell : NEC group D (=IIA), group C(=IIB3) and group B(=IIC), ETC.

**Optimum / optional Design & Arrangements** Stem Jacket type, Steam Tracing type

### APPLICATION

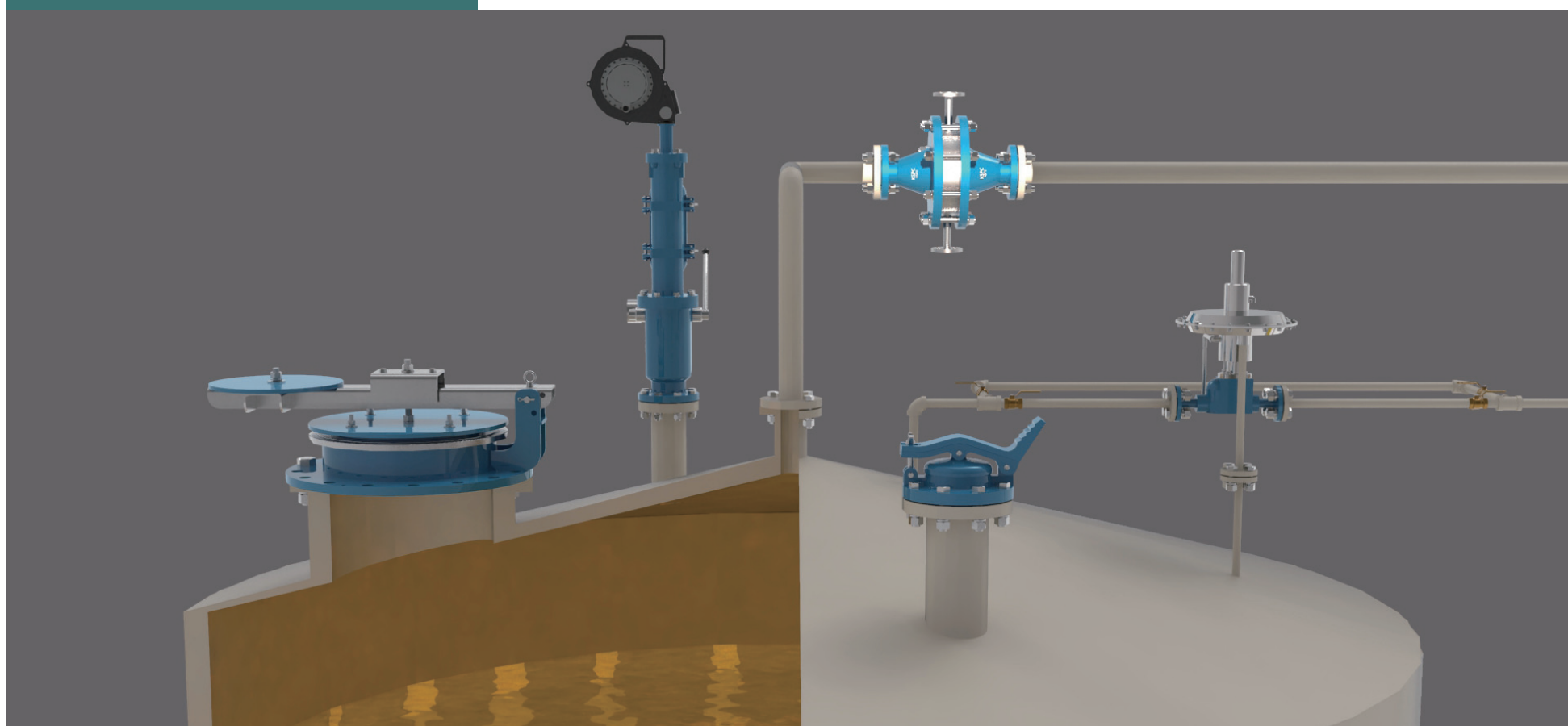

## OUTLINE DRAWING

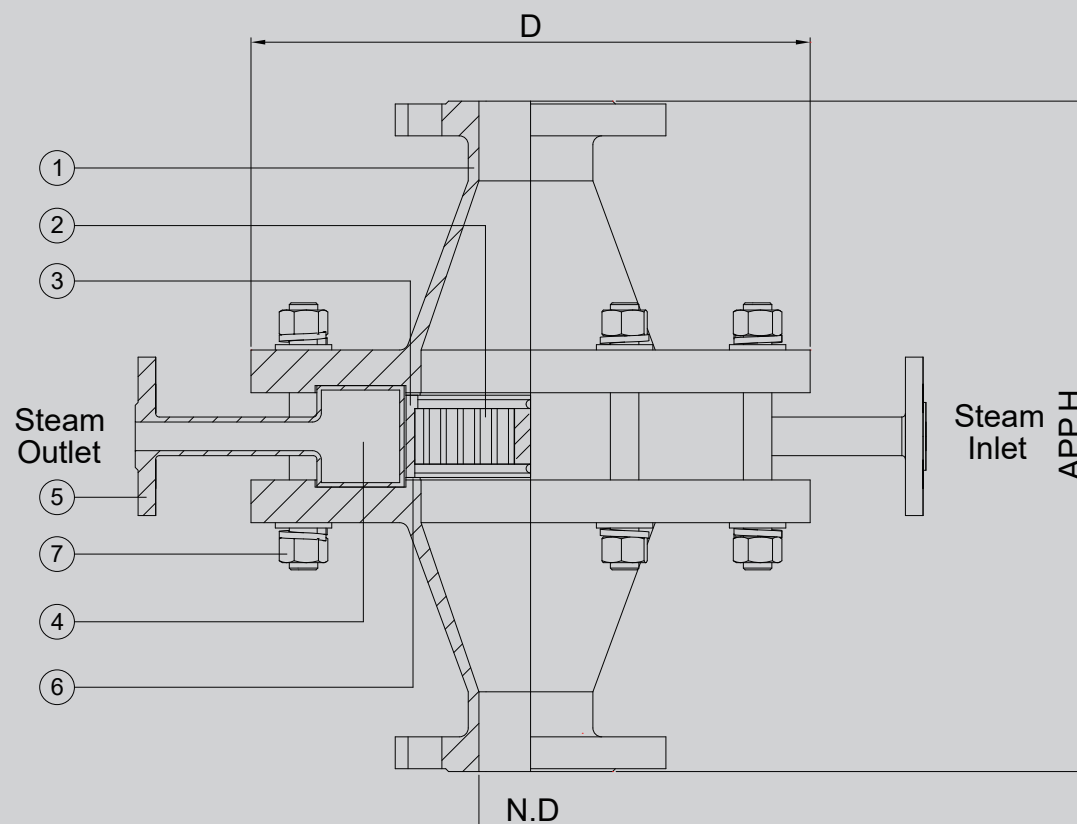

KSFI-J

Section 3.3  
KSFI-J

## DIMENSION TABLE

SIZE	2"	3"	4"	6"	8"	10"	12"
N.D	50	80	100	150	200	250	300
D	234	254	262	326	342	364	454
Approx. H	214	251	300	385	450	600	680

**NOTE** Standard Connection(ASME 150Lb flange) and JIS or different types are available upon request.

## COMPONENT MATERIAL

ITEM NO	COMPONENT	CARBON STEEL	SS304	SS316/SS316L
1	BODY	CARBON STEEL	SS304	SS316/316L
2	ELEMENT		SS316L	
3	ELEMENT HOUSING	SS304	SS304	SS316
4	STEAM JACKET	SS304	SS304	SS316L
5	STEAM LINE FLANGE	A182 F304	A182 F304	A182 F316L
6	GASKET		PTFE	
7	STUD BOLT/NUT	CARBON STEEL	SS304	SS316
STANDARD PAINTING		IN-OUT SIDE EPOXY 150 MICRON WITHOUT STAINLESS STEEL & ALUMINIUM PART		

## MAINTENANCE

- ⚠ Periodic inspection and maintenance is required. The cell assembly can be removed for cleaning purposes.
- ⚠ Cleaning can be accomplished by dipping the entire cell assembly into an appropriate solvent.
- ⚠ Care should be taken not to damage the cell openings as such deformations hamper the flow through the cell.
- ⚠ The gaskets should be inspected and replaced if necessary.