

# SECTION 3.5\_KSFL

## FLAME ARRESTER DEFLAGRATION PROOF IN-LINE

### INTRODUCTION

**The model KSFL** inline flame arrester is designed, manufactured, tested according to API 2000, British Standard Specification Code BS7244 and ISO 16852. The units are passive devices with no moving parts. They prevent the propagation of flame from the exposed side of the unit to the protected side by the use of a 316L stainless steel crimped metal ribbon type flame cell element. This construction produces a matrix of uniform opening that are carefully constructed to quench the flame by absorbing the heat.

### Operating Temperature @ Pressure

KSFL / DN 50 ~ DN 300

+ 60°C (=140°F) @ 0.11 Mpa

**Body Materials** Aluminium, Nodular Iron, Cast Steel, SS304, SS316, SS316L with various trims  
(Different materials available on request)

**Sizes range** DN 50 ~ DN 300 with ASME 150Lb flanges  
(Different connections available on request)

**Rules & Certifications** API 2000, BS7244 / ISO 16852 & ATEX / KFI  
Flame cell : NEC group D (=IIA), group C(=IIB3) and group B(=IIC), ETC.

**Optimum / optional Design & Arrangements** Stem Jacket type, Steam Tracing type

### APPLICATION

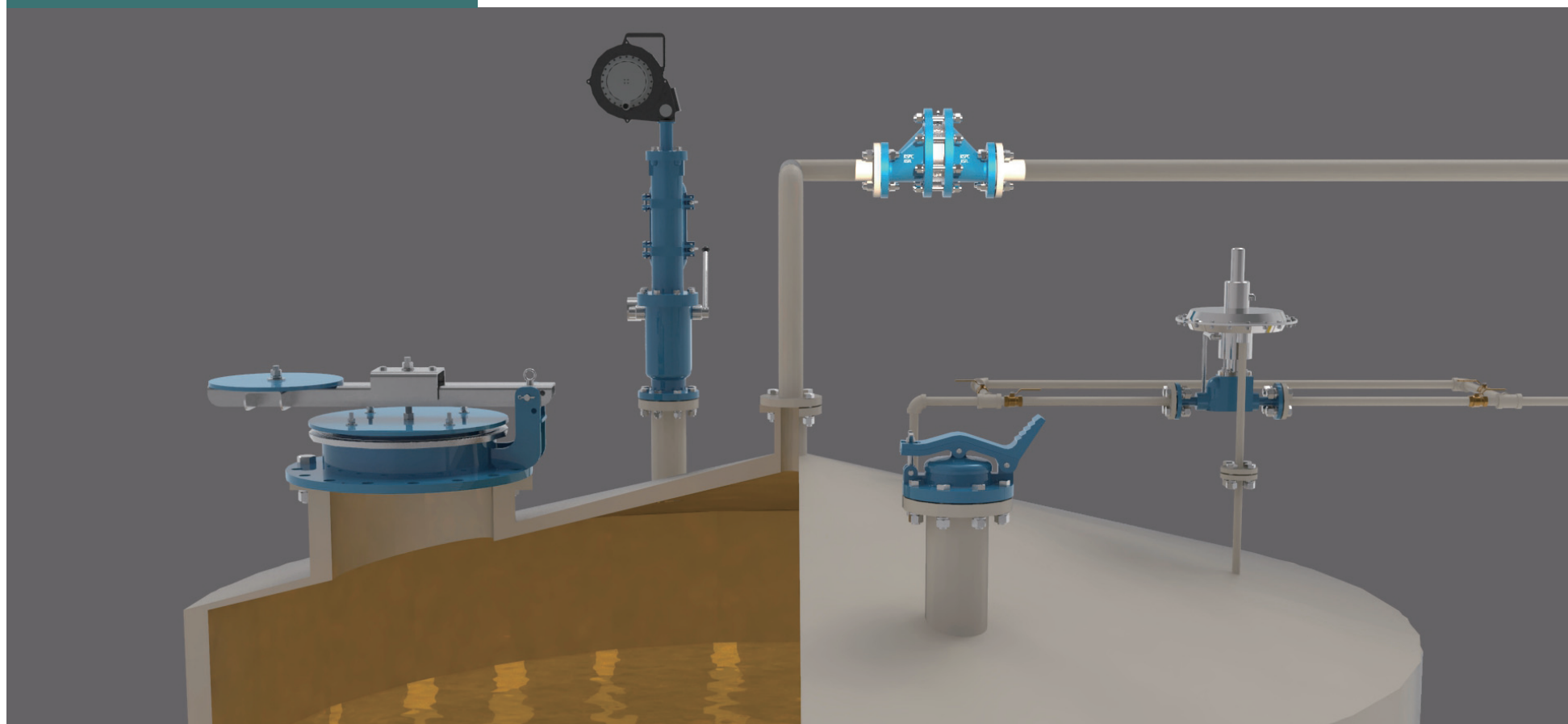

## OUTLINE DRAWING

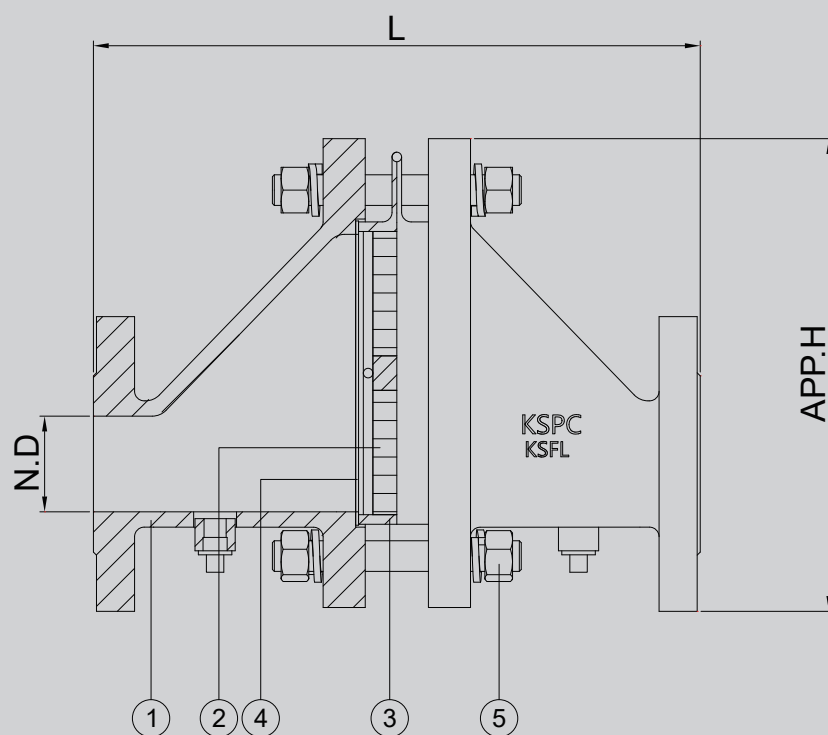

KSFL

Section 3.5  
KSFL

## DIMENSION TABLE

SIZE	2"	3"	4"	6"	8"	10"	12"
N.D	50	80	100	150	200	250	300
L	396	430	502	522	592	770	810
Approx. H	247	276	335	408	488	639	705

**NOTE** Standard Connection(ASME 150Lb flange) and JIS or different types are available upon request.

## COMPONENT MATERIAL

ITEM NO	COMPONENT	CARBON STEEL	STAINLESS STEEL
1	BODY	CAST or WELDED C.S	CAST or WELDED S.S
2	ELEMENT	316L	
3	ELEMENT HOUSING	SS304	SS304
4	GASKET	PTFE	
5	STUD BOLT/NUT	A193-B7 / A194-2H or STAINLESS STEEL	
STANDARD PAINTING		IN-OUT SIDE EPOXY 150 MICRON WITHOUT STAINLESS STEEL & ALUMINIUM PART	

## MAINTENANCE

- ⚠ Periodic inspection and maintenance is required. The cell assembly can be removed for cleaning purposes.
- ⚠ Cleaning can be accomplished by dipping the entire cell assembly into an appropriate solvent.
- ⚠ Care should be taken not to damage the cell openings as such deformations hamper the flow through the cell.
- ⚠ The gaskets should be inspected and replaced if necessary.